



# Robinets

Robinets à sphère  
Robinets à boisseau  
Fins de course  
Joints tournants

## Robinet à sphère

### 2 et 3 voies

Corps en acier zingué  
Pièces externes : en acier rectifié et chromé  
Joints : standard Buna N et joints POM

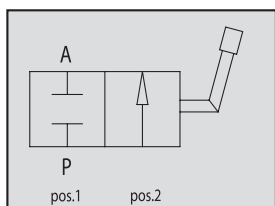

Ces vannes sont utilisées pour ouvrir ou fermer le débit d'huile dans un circuit, même à la pression maximale

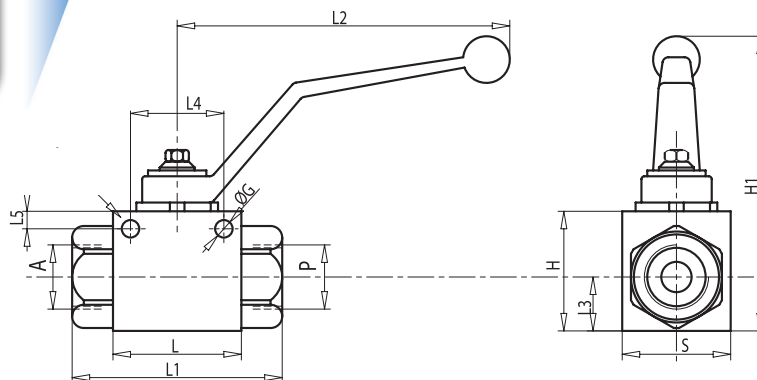

Type	Désignation	Pression maxi	Débit maxi	A P	L	L1	L2	L3	L4	L5	ØG	H	H1	S	Poids	Référence
		Bar	L/min	BSP	mm										Kg	
Small design	Robinet 2 voies 1/4"	500	25	G1/4"	39,4	69	110	14,3	34	4	5,1	33	87	26	0,490	500.014.2RAS2
	Robinet 2 voies 3/8"	500	35	G3/8"	41,8	71	110	15	34	4	5,1	35	89	30	0,644	500.038.2RAS2
	Robinet 2 voies 1/2"	500	60	G1/2"	44,4	83	110	18,3	36	4	5,1	40	94	35	0,757	500.012.2RAS2
Standard	Robinet 2 voies 1/4"	500	25	G1/4"	42,4	71	110	14,5	34	4,5	5,25	35	87	30	0,490	500.014.2RAS0
	Robinet 2 voies 3/8"	500	35	G3/8"	44,4	73	110	17,4	34	4,5	5,25	40	93	35	0,644	500.038.2RAS0
	Robinet 2 voies 1/2"	500	60	G1/2"	48,4	83	110	19,7	36	5	5,25	43	97	37	0,757	500.012.2RAS0
	Robinet 2 voies 3/4"	420	100	G3/4"	62,5	95	180	25,4	50	6	6,25	57	105	49	1,438	500.034.2RAS0
	Robinet 2 voies 1"	420	180	G1"	66,5	112	180	29,5	50	6	6,25	65	113	55	2,223	500.100.2RAS0
	Robinet 2 voies 1 1/4"	350	220	G1 1/4"	66,5	120	180	29,5	50	6	6,25	65	113	55	2,273	500.114.2RAS0
	Robinet 2 voies 1 1/2"	350	260	G1 1/2"	66,5	124	180	29,5	50	6	6,25	65	113	55	2,386	500.112.2RAS0

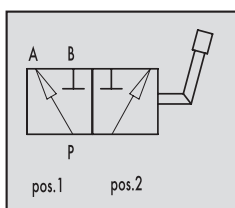

Ces vannes sont utilisées pour détourner le flux d'entrée vers 2 autres ports (schéma L).

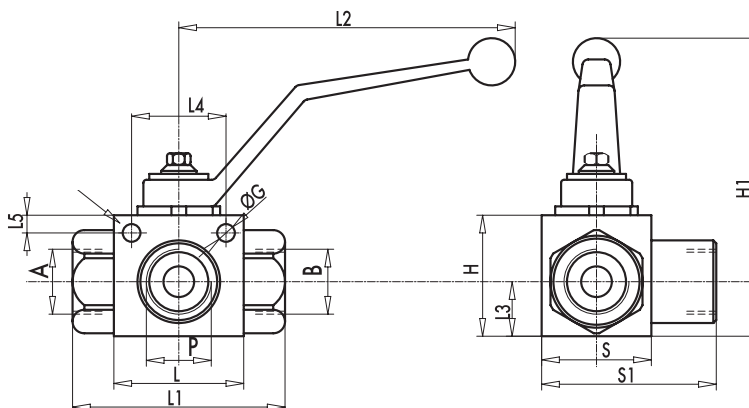

Désignation	Pression maxi	Débit maxi	A B P	L	L1	L2	L3	L4	L5	ØG	H	H1	S	S1	Poids	Référence
	Bar	L/min	BSP	mm										Kg		
Robinet 3 voies 1/4"	500	25	G1/4"	42,5	70	110	14	34	4,5	5,25	35	90	25	47	0,500	500.014.3RAS0
Robinet 3 voies 3/8"	500	35	G3/8"	44,5	76	110	19	34	4,5	5,25	40	95	30	49	0,700	500.038.3RAS0
Robinet 3 voies 1/2"	500	60	G1/2"	48,5	83	110	17,5	36	5	5,25	41	95	40	60	0,800	500.012.3RAS0
Robinet 3 voies 3/4"	420	100	G3/4"	62,5	95	180	24,5	50	6	6,25	55	110	55	81	1,500	500.034.3RAS0
Robinet 3 voies 1"	420	180	G1"	66,5	110	180	26,5	50	6	6,25	60	120	60	93	2,350	500.100.3RAS0
Robinet 3 voies 1 1/4"	350	220	G1 1/4"	66,5	123	180	26,5	50	6	6,25	60	120	60	93	2,500	500.114.3RAS0
Robinet 3 voies 1 1/2"	350	260	G1 1/2"	66,5	128	180	26,5	50	6	6,25	60	120	60	93	2,700	500.112.3RAS0



## Robinet à sphère

### 3 voies - 500 bar

Corps en acier

Pièces externes : en acier trempé et rectifié

Joints : standard Buna N

Étanchéité : fuite mineure

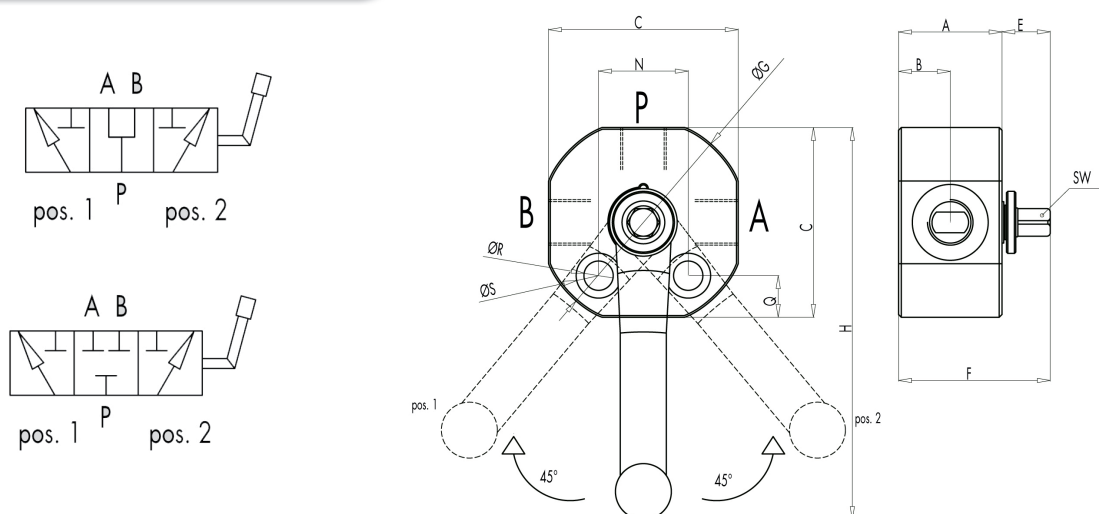

## Usages et applications

Le débit de dérivation est utilisé pour détourner le flux vers 2 sorties différentes.

**Application :** Avec le levier en position 1, le débit est connecté vers le port A; avec le levier en position 2, le débit est connecté vers le port B. Avec le levier en position centrale P, A et B sont tous les 2 connectés (centre ouvert).

Désignation	Pression maxi	Débit maxi	Poids	A	B	C	E	F	ØG	H	L	LW	N	Q	ØR	ØS	SW	Référence
	Bar	L/min																
Robinet 3 voies HP 1/4"	500	20	0,65	33	15	55	16	49	62	110	15,5	6	26	10	8,5	13,5	9	500.014.05001
Robinet 3 voies HP 3/8"	500	35	0,72	38	17,5	55	16	54	62	110	15,5	8	26	10	8,5	13,5	9	500.038.05000
Robinet 3 voies HP 1/2"	500	60	0,92	43	20	60	16	59	67	110	17	11	32	11	10,5	13,5	9	500.012.05001
Robinet 3 voies HP 3/4"	500	100	1,57	48	22,5	75	20,5	68,5	82	180	21	12	32	14	10,5	16,5	14	500.034.05001
Robinet 3 voies HP 1"	500	180	2,17	53	25	85	20,5	73,5	97	180	21	16	32	14	10,5	16,5	14	500.100.05000



## Robinetts à boisseau

### 3 voies type DF

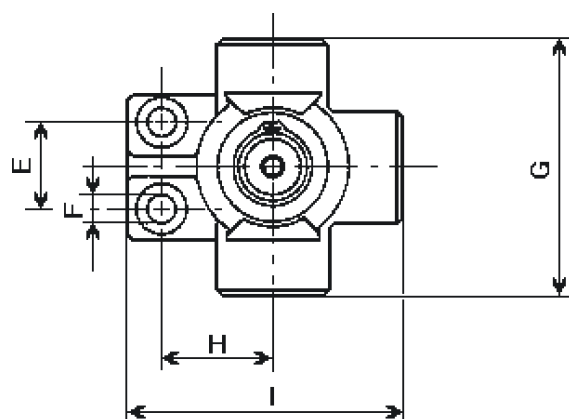
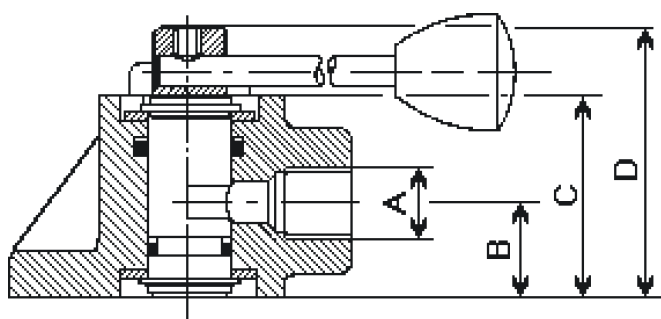

### Versions disponibles

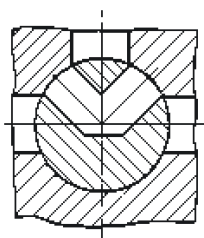

**B**

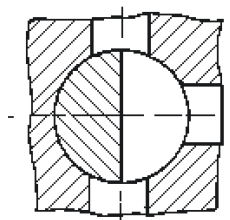

**F**

A	B	C	D	E	F	G	H	I	DEBIT MAXI	PRESSION MAXI	VERSION
Gaz	mm.								Lt/Min.	Bar	
3/8"	21	46	62	25	8,5	74	31	78	35	250	B - F
1/2"	24	54	70	32	10,5	86	36	92	50	250	B - F
3/4"	28	61	78	32	11	90	39	100	80	250	B - F
1"	32	66	88	32	11	96	47	111	120	200	B - F
1 1/2"	44	91	116	45	11	125	62	142	180	250	F



## Robineets à boisseau

### 4 voies type IF

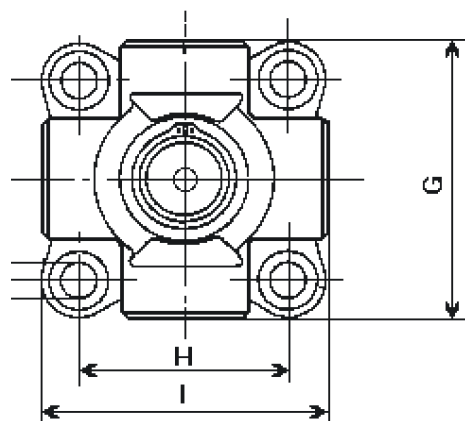
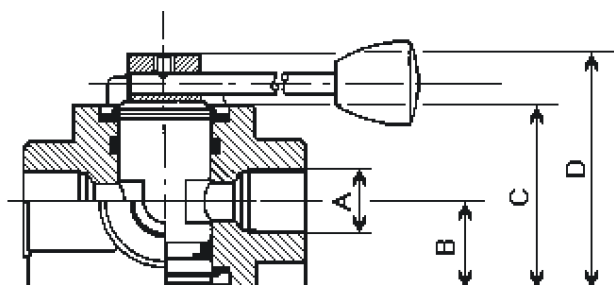

### Versions disponibles

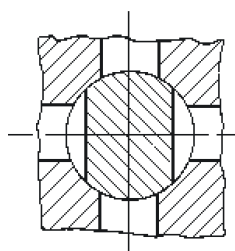

**D**

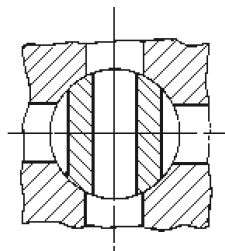

**E**

A	B	C	D	E	F	G	H	I	DEBIT MAXI	PRESSION MAXI	VERSION
Gaz									Lt/Min.	Bar	
mm.											
3/8"	24	53	70	54	9	78	54	78	35	250	D - E
1/2"	28	57	78	66	10,- 5	91	66	91	45	250	D - E
3/4"	32	66	88	70	10,- 5	96	70	96	75	250	D - E



## Robinets à boisseau

6 voies type DFD

8 voies type IFD

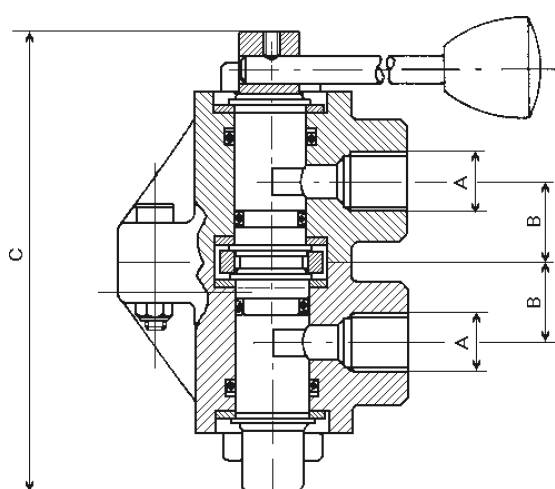

DFD

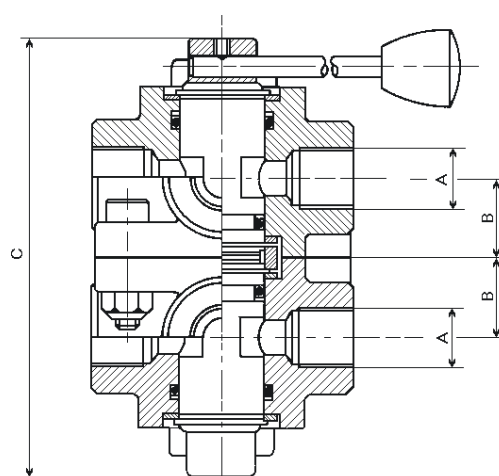

IFD

### Versions disponibles

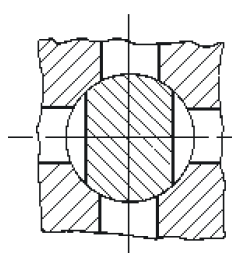

D

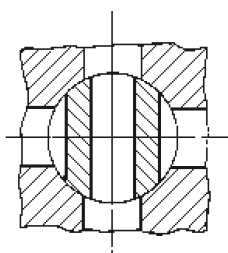

E

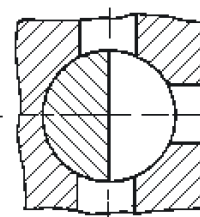

F

DFD			DEBIT MAXI	PRESSION MAXI	VERSION
A	B	C			
Gaz	mm.		Lt/Min.	Bar	
3/8"	21	124	35	250	F
1/2"	24	140	50	250	F
3/4"	28	156	80	250	F
1"	32	176	120	200	F
1 1/2"	44	232	180	250	F

IFD			DEBIT MAXI	PRESSION MAXI	VERSION
A	B	C			
Gaz	mm.		Lt/Min.	Bar	
3/8"	24	140	35	250	D - E
1/2"	28	156	45	250	D - E
3/4"	32	176	75	250	D - E
1"	-	-	-	-	-
1 1/2"	-	-	-	-	-



## Fin de course

# En tirant ou en poussant

Pression maxi : 350 bar

Normalement fermé

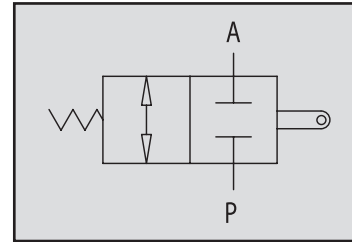

V-FCR 2T 60-80

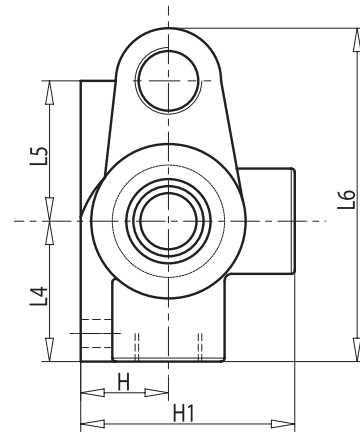
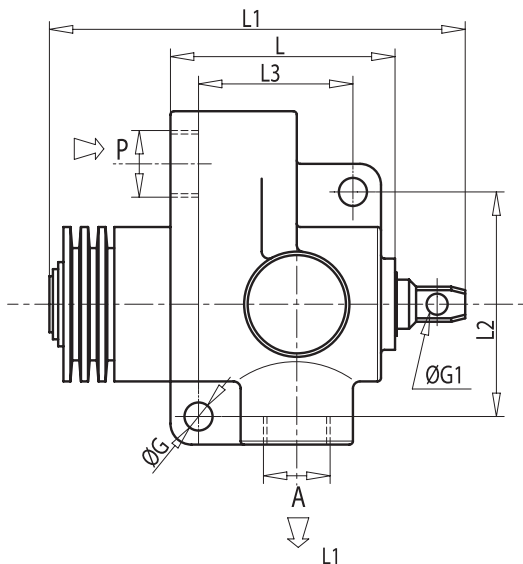

V-FCR 2T 120

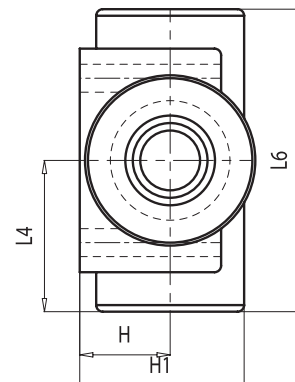
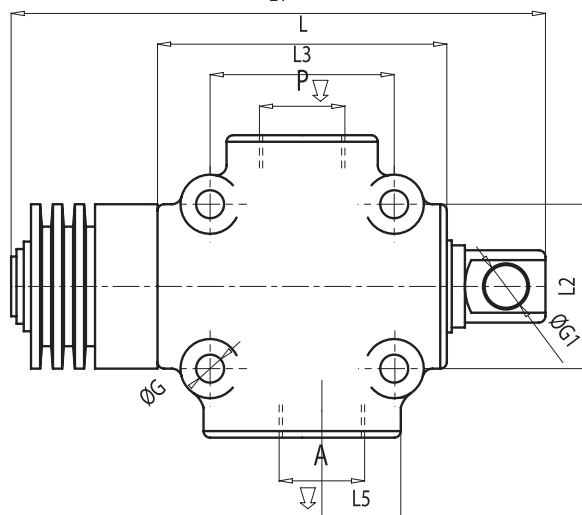

Désignation	Débit maxi	A-B	L	L1	L2	L3	L4	L5	L6	ØG	ØG1	H	H1	Poids	Référence
	L/min	P-T													
V-FCR2T60	60	3/8"	69	130	66	45	45	41	103	8,5	6,5	26	68	1,648	511.038.02011
V-FCR2T80	80	1/2"	69	130	66	45	45	41	103	8,5	6,5	26	68	1,652	511.012.02021
V-FCR2T120	120	3/4	88	179	50	56	46	23,5	92	8,5	13	27,5	50	2,204	211.034.02031



## Fin de course

# En tirant ou en poussant

Pression maxi : 350 bar

Normalement ouvert

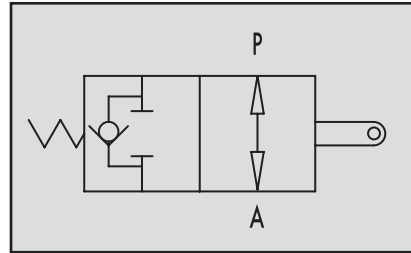

V-FCR 1T 60-80

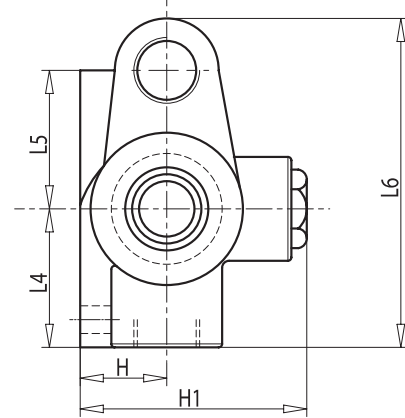
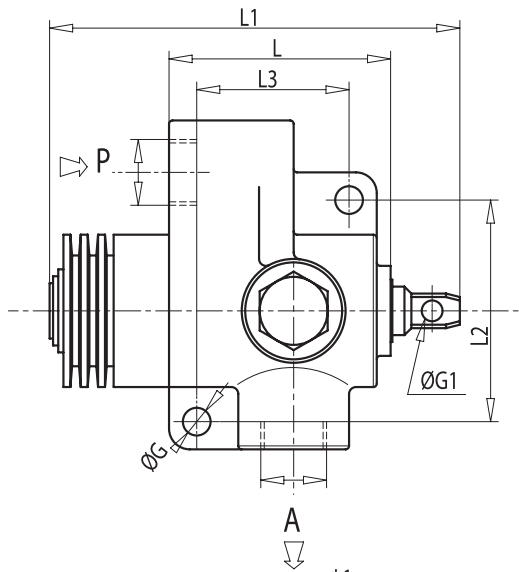

V-FCR 1T 120

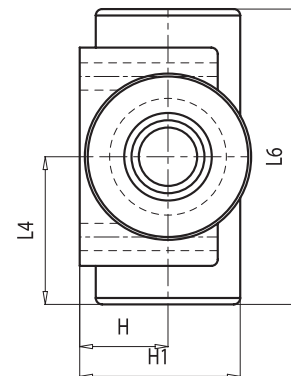
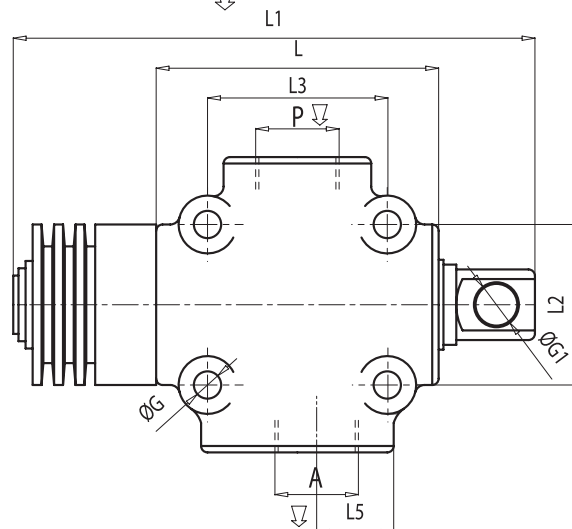

Désignation	Débit maxi L/min	A-B P-T Gaz	L	L1	L2	L3	L4	L5	L6	ØG	ØG1	H	H1	Poids Kg	Référence
			MM												
V-FCR1T60	60	3/8"	69	130	66	45	45	41	103	8,5	6,5	26	68	1,628	511.038.02010
V-FCR1T80	80	1/2"	69	130	66	45	45	41	103	8,5	6,5	26	68	1,616	511.012.02020
V-FCR1T120	120	3/4	88	173	50	56	46	23,5	92	8,5	13	27,5	50	2,112	211.034.02030



## Fin de course

# À pousser - normalement fermé

Pression maxi : 350 bar

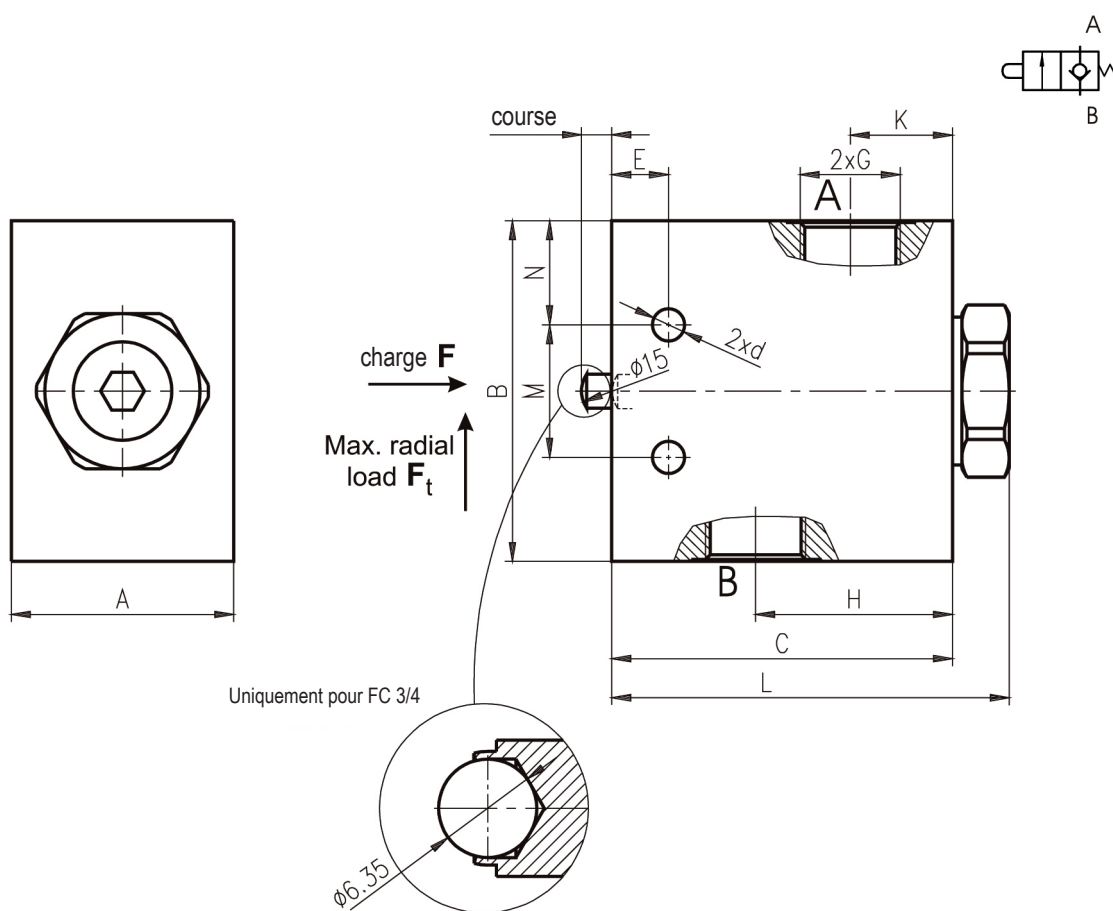

Désignation	Pression maxi	Débit maxi	Charge maxi		L	A	B	C	M	N	E	K	H	G	d	course	Référence
	Bar		L/min	F (N)													
FC 3/8	350	30	F= 11,5.P/bar	80	71	30	60	65	35	12,5	15	18	32,5	G3/8"	8,5	8,5±1	511.038.05021
FC 1/2														G1/2"			511.012.05021
FC 3/4														G3/4"			511.034.05021

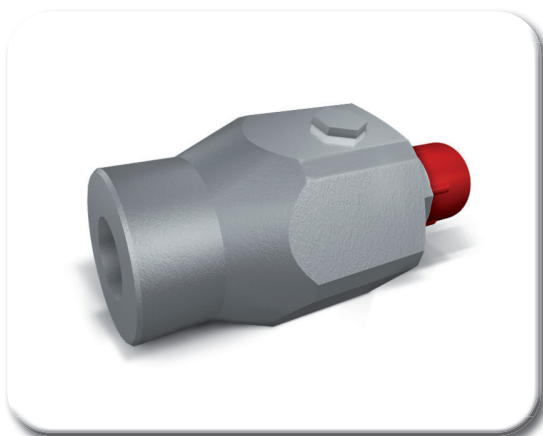

## Raccord tournant

### Type GGL

- Utilisé dans le cas où un flexible doit subir une rotation lors de la course d'un vérin
- La vitesse de rotation doit être modérée et non continue

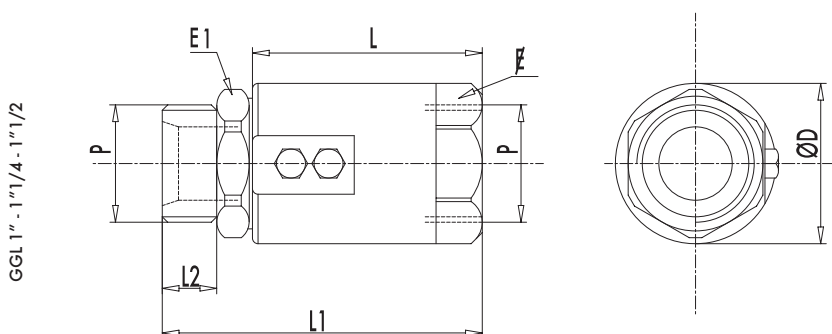
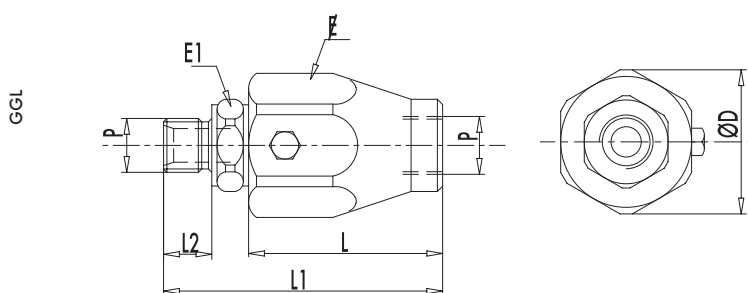
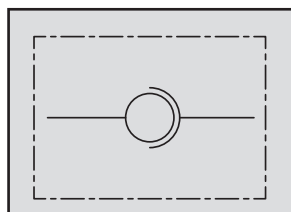

Désignation	Débit maxi	Pression de rotation maxi	Pression maxi	P	L	L1	L2	E1	∅	ØD	Poids	Référence
	L/min	Bar	Bar	Gaz	MM						Kg	
GGL 1/4"	25	200	400	G1/4"	42	61	11	19	30	33	0,206	408.014.G1050
GGL 3/8	35	200	400	G3/8"	44	66	14	24	34	37	0,264	408.038.G1060
GGL 1/2"	60	150	300	G1/2"	47	71	15	27	36	40	0,338	408.012.G1070
GGL 3/4"	100	150	300	G3/4"	60	89	19	34	45	49,5	0,546	408.034.G1080
GGL 1"	180	100	300	G1"	65	98	21	41	50	54,5	0,910	408.100.G1090
GGL ° 1 1/4"	270	100	300	G 1 1/4"	63	101	24	50	55	59,5	1,100	408.114.G1091
GGL 1 1/2"	350	80	300	G 1 1/2"	70	110	25	55	65	69,5	1,610	408.112.G1092
GGL ° 2"	700	50	250	G2"	75	119	28	65	75	84,5	3,300	408.200.G1093

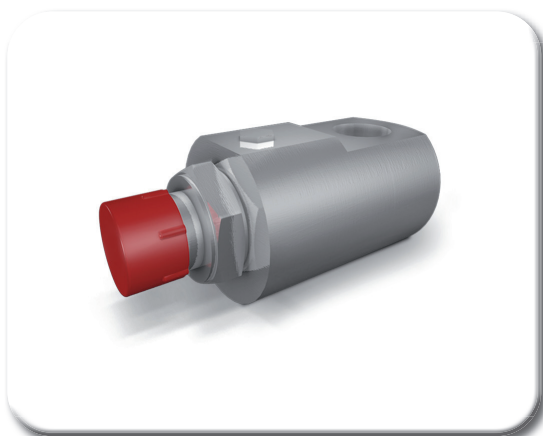

## Raccord tournant 90°

### Type GG 90°

- Utilisé dans le cas où un flexible doit subir une rotation lors de la course d'un vérin
- Montage à 90°
- La vitesse de rotation doit être modérée et non continue

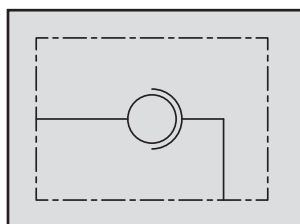

GG 90°

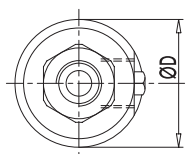
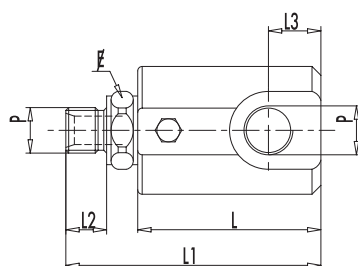

GG 90° 1" - 1 1/4" - 1 1/2"

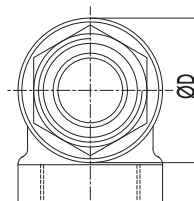
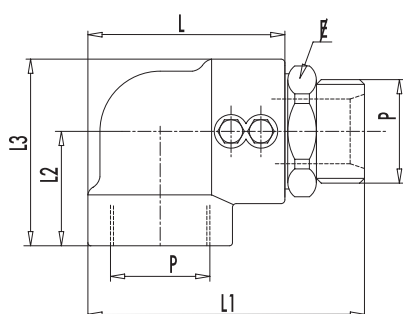

Désignation	Débit maxi	Pression de rotation maxi	Pression maxi	P	L	L1	L2	L3	∠	ØD	Poids	Référence
	L/min											
GG 90° 1/4"	25	200	400	G1/4"	50	69	11	11	19	34	0,312	408.014.G0990
GG 90° 3/8"	35	200	400	G3/8"	54	76	14	13	24	38	0,418	408.038.G1010
GG 90° 1/2"	60	150	300	G1/2"	63	87	15	14	27	40	0,522	408.012.G1020
GG 90° 3/4"	100	150	300	G3/4"	74	104	19	19,5	34	54,5	0,898	408.034.G1030
GG 90° 1"	180	100	300	G1"	87	119	21	24	41	60	1,122	408.100.G1040
GG 90° 1 1/4"	270	100	300	G 1 1/4"	84	119,5	52	82	50	63	1,746	408.114.G1042
GG 90° 1 1/2"	350	80	300	G 1 1/2"	102	140	62	101	55	77	3,070	408.112.G1043
GG 90° 2"	700	50	250	G2"	107	151	64	107	65	84	3,300	408.200.G1044