

Masse 10,8 kg x 2 = 21,6 kg

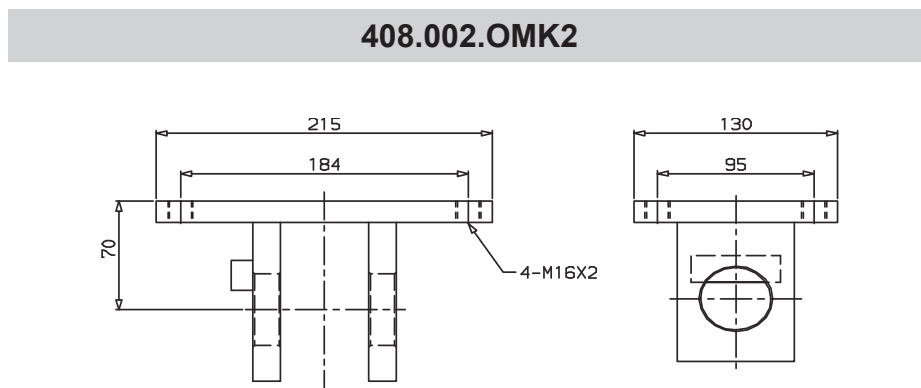

408.002.OMK2 pour vérins 4 ou 5 expansions
Masse 6 kg

VÉRINS AVEC FIXATION TOURILLON / ŒIL Ultra

CS18 LE

Code des vérins			Nombre d'expansions	Course (mm)	Masse (kg)	Volume d'huile balayé (l)	Capacité de basculement (tonne)		Longueur du corps (mm)		A - Entraxe de fixation (mm) Tolérance +40/-0	B - Entraxe d'orifice (mm)	Type d'orifice
							mini	Maxi	mini	Maxi			
413.418.550301	6233	A02	5	6233	241	109	32	43	8250	9250	1513	700	BSP
413.418.550301	6483	A02	5	6483	248	113	34	43	8500	9500	1563	700	BSP
413.418.550301	6733	A02	5	6733	256	118	31	39	8750	9750	1613	700	BSP
413.418.550301	6883	A02	5	6883	259	120	31	39	8750	9750	1660	700	BSP
413.418.550301	7033	A02	5	7033	264	123	31	40	8750	9750	1673	700	BSP
413.418.550301	7233	A02	5	7233	276	127	31	38	9250	10250	1713	700	BSP
413.418.550301	7733	A02	5	7733	291	136	25	31	9750	10750	1813	700	BSP
413.418.550301	7983	A02	5	7983	298	140	25	31	10000	11000	1863	700	BSP

SPÉCIAUX

413.418.550319	5483	S02	5	5483	241	102	30	47	7000	8000	1513	700	BSP
413.418.550310	6583	J02	5	6583	263	119	32	42	8500	9500	1663	700	BSP
413.418.551201	6983	A06	5	6983	272	122	33	42	8750	9750	1673	700	SAE
413.418.550101	7233	A03	5	7233	278	127	32	40	9000	10000	1738	190	BSP
413.418.550301	7233	A03	5	7233	278	131	28	35	9000	10000	1738	700	BSP
413.418.550301	7483	A02	5	7483	285	131	28	34	9500	10500	1763	700	BSP
413.418.551201	7483	A02	5	7483	286	134	28	34	9250	10250	1763	700	SAE
413.418.551201	7633	A02	5	7633	287	134	28	36	9250	10250	1793	700	BSP
413.418.550312	7983	L02	5	7983	315	144	30	37	9750	10750	1963	700	BSP
413.418.551207	8183	G02	5	8183	316	146	26	32	10000	11000	1963	700	SAE
413.418.550101	8233	A02	5	8233	307	144	21	26	10000	11000	1913	190	BSP
413.418.551201	8233	A02	5	8233	307	144	21	26	10000	11000	1913	700	SAE