

VÉRINS HYDRAULIQUES TÉLESCOPIQUES

Articulation supérieure - 2 expansions - série lourde

P maxi de service : 220 bar - Poids total basculable : 9 tonnes à 180 bar

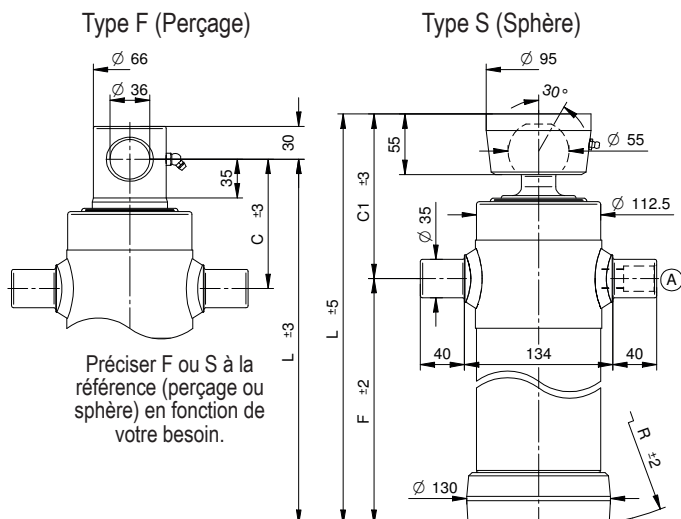

Préciser F ou S à la référence (perçage ou sphère) en fonction de votre besoin.

STANDARD



OPTIONS

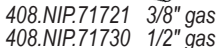
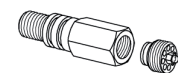
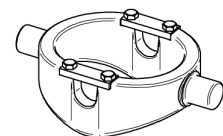

Course	Ø Expansions		C	C1	F	L	L1	R	L. expansion	Poids		Volume d'huile	Référence
	mm	Ø 68 6,5 t.								Ø 88 10,9 t.	F		
590	•	•	122	154	313	435	467	320	370	30	31,5	3	406.020.4021 S ou F
690	•	•	122	154	363	485	517	370	420	33,5	35	4	406.020.4022 S ou F
790	•	•	122	154	413	535	567	420	470	37	38	4,5	406.020.4024 S ou F
890	•	•	122	154	463	585	617	470	520	40,5	41,5	5	406.020.4025 S ou F

P maxi de service : 220 bar - Poids total basculable : 13 tonnes à 180 bar

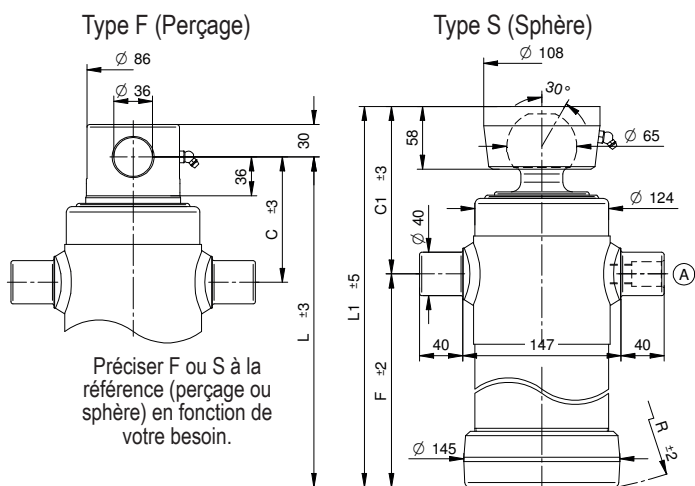

Préciser F ou S à la référence (perçage ou sphère) en fonction de votre besoin.

STANDARD

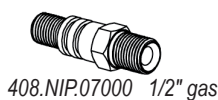

OPTIONS

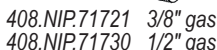
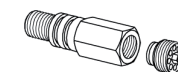
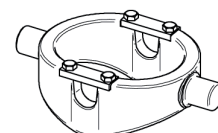

Course	Ø Expansions		C	C1	F	L	L1	R	L. expansion	Poids		Volume d'huile	Référence
	mm	Ø 88 10,9 t.								Ø 107 16,1 t.	F		
690	•	•	118	157	364	482	521	373	420	32	33	5,8	406.020.4023 S ou F
890	•	•	118	157	464	582	621	472	520	37,5	38,5	7,5	406.020.4026 S ou F
1030	•	•	148	187	534	682	721	570	620	43,5	44,5	9	406.020.4027 S ou F
1190	•	•	148	187	614	762	801	650	700	48	49	10,5	406.020.4028 S ou F
1390	•	•	148	187	714	862	901	750	800	54	54,5	12	406.020.4029 S ou F