

VÉRINS HYDRAULIQUES TÉLESCOPIQUES

Articulation supérieure - 5 expansions - série légère

P maxi de service : 200 bar - Poids total basculable : 5 tonnes à 180 bar

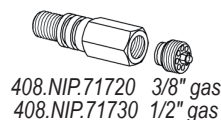
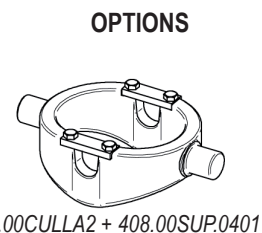
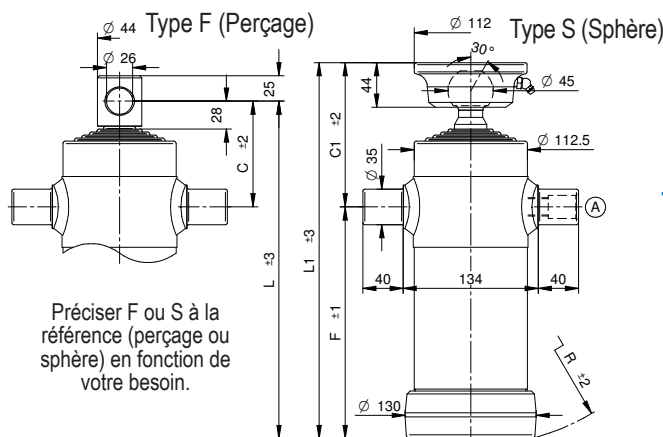

Course	Ø Expansions Tonnage					C	C1	F	L	L1	R	L. expansion	Poids		Volume d'huile	Référence
	Ø 32	Ø 46	Ø 61	Ø 76	Ø 91								F	S		
mm	1,4 t.	2,9 t.	5,2 t.	8,1 t.	11,7 t.	mm					Kg		Litre	S (sphère) F (perçage)		
680	•	•	•	•	•	106	144	158	264	302	166	210	16,5	18,5	2,5	405.050.5020 S ou F
830	•	•	•	•	•	106	144	188	294	322	196	240	18	20	3	405.050.5021 S ou F
1030	•	•	•	•	•	106	144	228	334	372	236	280	21	23	4	405.050.5022 S ou F
1230	•	•	•	•	•	110	148	263	373	471	276	320	23	25	4,5	405.050.5023 S ou F

P maxi de service : 200 bar - Poids total basculable : 8 tonnes à 180 bar

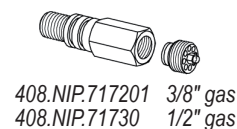
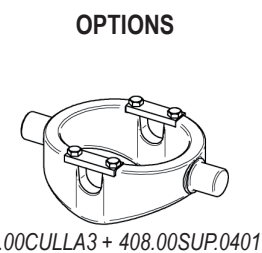
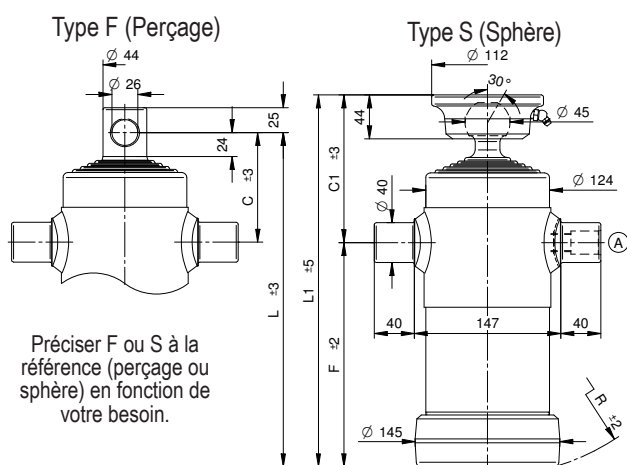

Course	Ø Expansions Tonnage					C	C1	F	L	L1	R	L. expansion	Poids		Volume d'huile	Référence
	Ø 46	Ø 61	Ø 76	Ø 91	Ø 107								F	S		
mm	2,9 t.	5,2 t.	8,1 t.	11,7 t.	16,1 t.	mm					Kg		Litre	S (sphère) F (perçage)		
490	•	•	•	•	•	99	150	94	193	231	125	150	16	19	2,5	405.050.3090 S ou F
685	•	•	•	•	•	112	150	154	266	304	172	210	21	22,5	4	405.050.3050 S ou F
760	•	•	•	•	•	112	150	169	281	319	185	225	22	23,5	4	405.050.3098 S ou F
835	•	•	•	•	•	112	150	184	296	334	200	240	23	25	4,5	405.050.3091 S ou F
1035	•	•	•	•	•	112	150	224	336	374	237	280	25,5	27,5	5,5	405.050.3092 S ou F
1185	•	•	•	•	•	112	150	254	366	404	265	310	28	29,5	6,5	405.050.3093 S ou F
1310	•	•	•	•	•	112	150	279	391	429	290	335	29,5	31	7	405.050.3097 S ou F
1485	•	•	•	•	•	112	150	314	426	464	325	370	32	34	8	405.050.3094 S ou F
1885	•	•	•	•	•	112	150	394	506	544	402	450	37	39,5	10,5	405.050.3099 S ou F
2135	•	•	•	•	•	112	150	444	556	594	450	500	41	43	12	405.050.3095 S ou F
2485	•	•	•	•	•	112	150	514	626	664	520	570	46	48	14	405.050.3096 S ou F