

CARATTERISTICHE TECNICHE DEL GRUPPO DI VENTILAZIONE

TECHNICAL FEATURES

Tipologia Type	Frequenza Frequency Hz	Tensione Voltage V	N° Giri/min RPM	Potenza Power kW	Diam. Ventola Ø FAN (mm)	dB (A)	L (mm)	Q air (m³/h)	Cap. (lt)	Peso Weight (kg)	IP
03	50/60	230/400	1380/1540	0.2/0.28	450	75	183	6040	4.9	27	44
14	50 60	230/400 276/480	1390 1685	0.75 0.90	450	73	445	6830	4.9	30	55
12	DC	12	3005	0.106	280	74	237,5	4200	4.9	24	68
24	DC	24	3005	0.106	280	74	237.5	4200	4.9	24	68
G2	-	-	-	-	450	-	243.5	-	4.9	23	-

Portata olio consigliata da 50 a 180 (lt/min)
Suggested oil flow from 50 to 180 (lt/min)

(x2) = doppio motore
(x2) = double engine

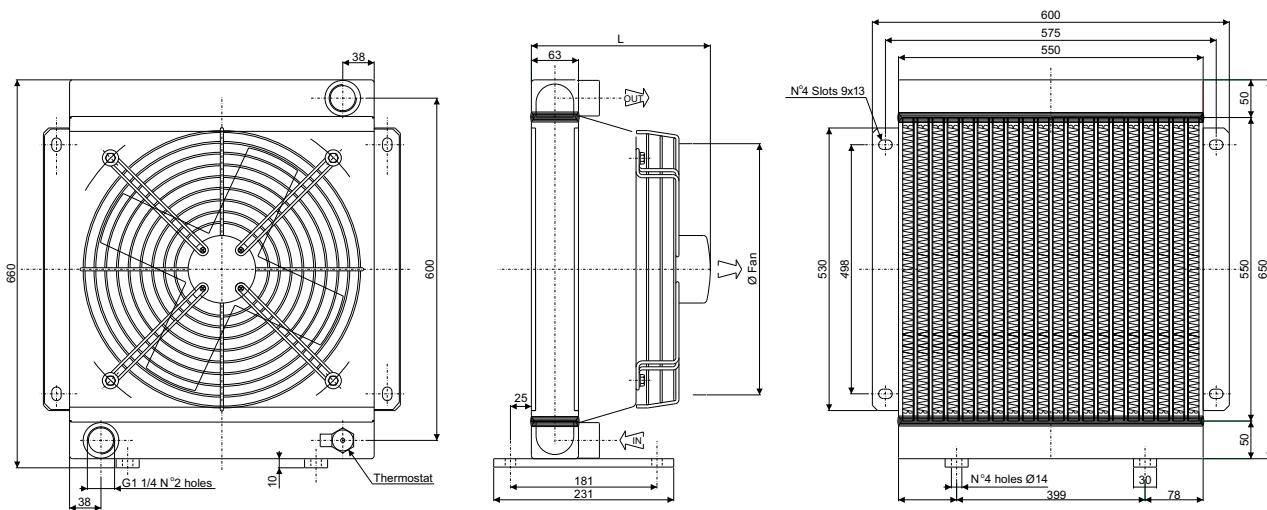

Coefficiente di correzione

Correction factor

CST	10	15	20	32	40	50	60	80	100	200
F	0.51	0.66	0.76	1	1.22	1.4	1.6	1.9	2.1	3.4

Diagramma di rendimento

Performance diagram

5

Diagramma perdite di carico (32 cst)

Pressure drop diagram (32 cst)

