

ECHANGEURS DE TEMPERATURE AIR/HUILE SERIE ST

Type ST150

CARATTERISTICHE TECNICHE DEL GRUPPO DI VENTILAZIONE TECHNICAL FEATURES

Tipologia Type	Frequenza Frequency Hz	Tensione Voltage V	Giri/min RPM N.°	Potenza Power kW	Ø ventola Ø FAN (mm)	dB (A)	Q air (m ³ /h)	Cap. (lt)	Peso Weight (kg)	IP
12	DC	12	3090	0.218	305	82.67	2617	1.5	14	68
24	DC	24	3090	0.218	305	82.67	2324	1.5	14	68

Portata olio consigliata da 35 a 140 (lt/min)
Suggested oil flow from 35 to 140 (lt/min)

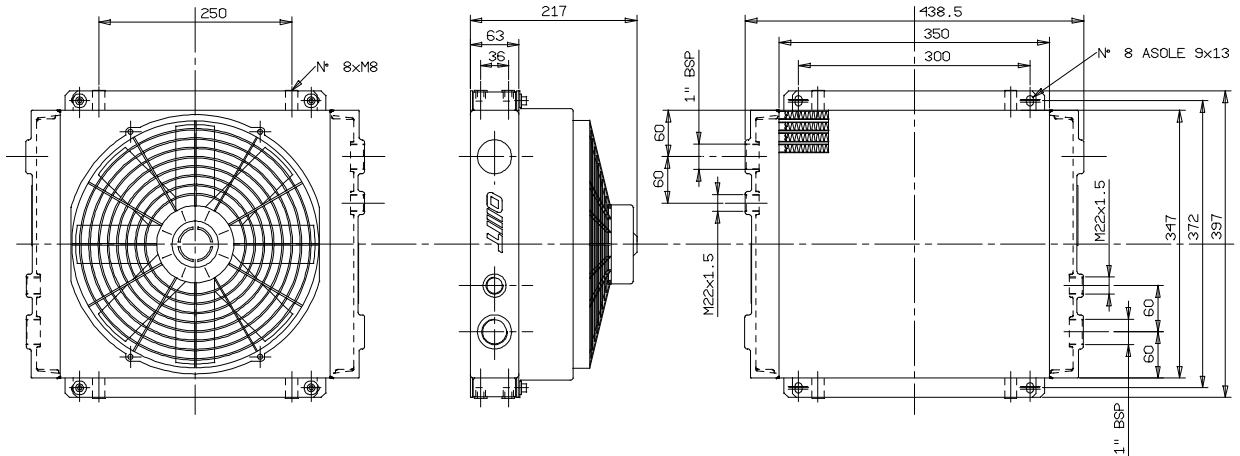

COEFFICIENTE DI CORREZIONE CORRECTION FACTOR

CST	10	15	20	32	40	50	60	80	100	200
F	0.51	0.66	0.76	1	1.22	1.4	1.6	1.9	2.1	3.4

DIAGRAMMA DI RENDIMENTO PERFORMANCE DIAGRAM

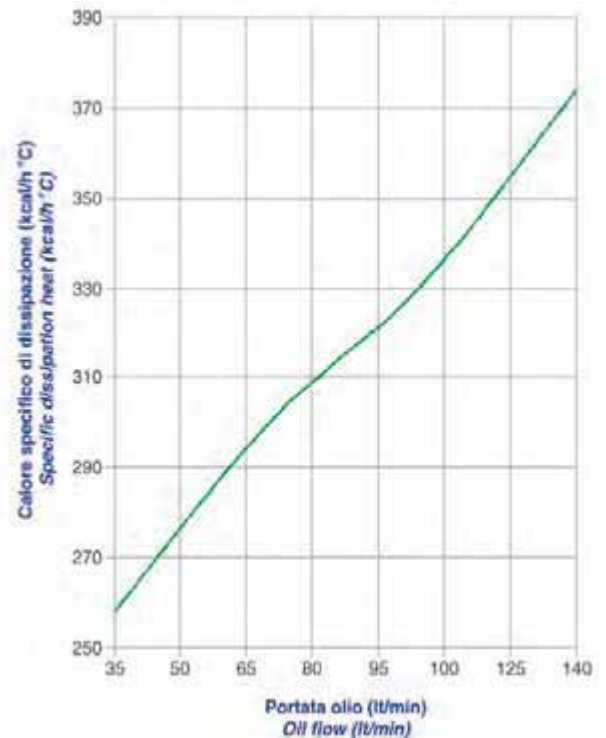

DIAGRAMMA PERDITE DI CARICO (32 cst) PRESSURE DROP DIAGRAM (32 cst)

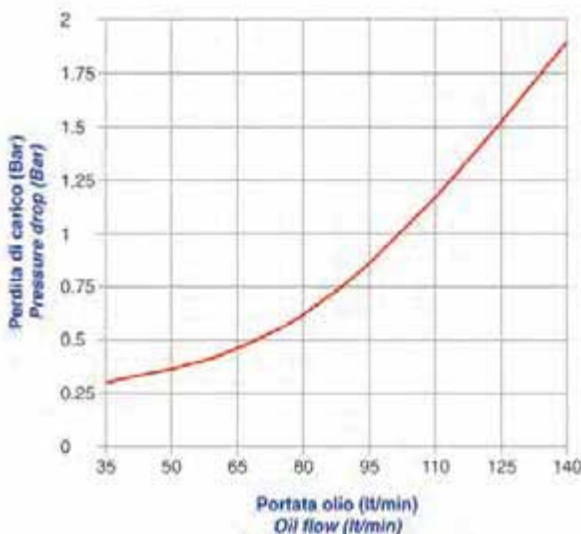

Le dimensioni di ingombro e le caratteristiche tecniche non sono impegnative
Over-all dimensions and technical characteristic are not binding